

# UNIQUE

XTRA TUFF VICES

**UNIQUE COMPOUND  
SLIDING TABLES  
WITH CALIBRATED WHEEL &  
SWIVELING TABLE**

VICES

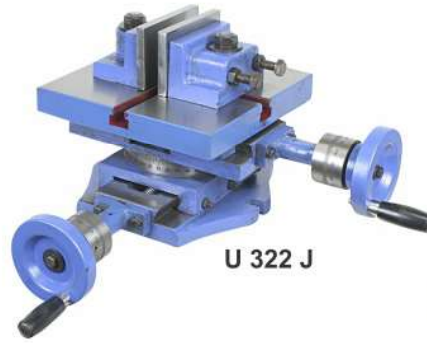

U 322 J



U 318N

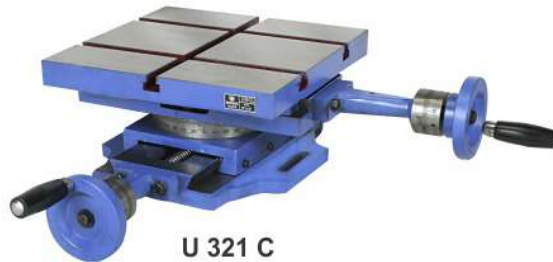

U 321 C



U 320

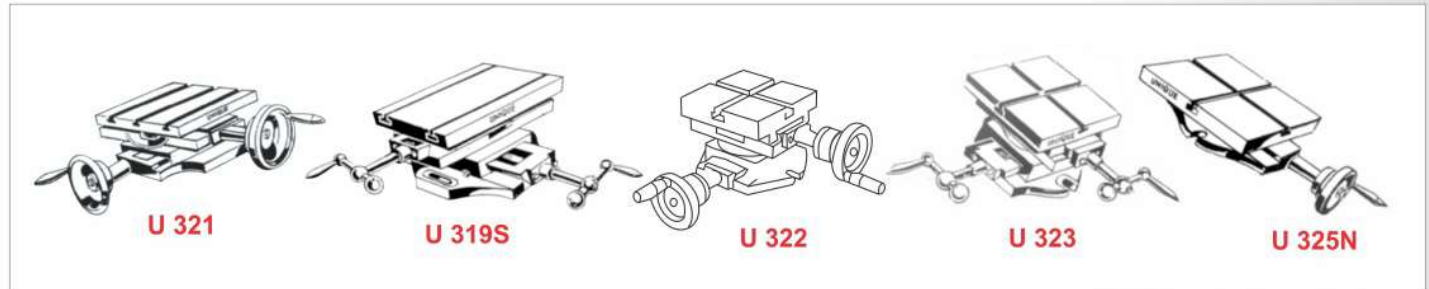

## FEATURES

- Unique Precision Sliding Tables are meant for accurate boring, drilling grinding and milling operations.
- Grey iron casting properly machined and grinded with a Unique process provides accuracy well within 0.01mm/100mm tolerance.
- Toughened lead screw having acme threads running smoothly in phosphorus Bronze Nut.
- Dovetail slides have adjustable steel ribs for smooth running and adjustment.

## SPECIFICATIONS

Code No.	U320		U321 & U321C			U322J	U322				U325N &U318N	U325N &U318N	U319	U319S	U323
SIZE IN INCHES	12x8	12x6	12x12	12x20	16x16	8x8	4x4	6x6	8x8	10x10	8x8	6x6	12x8	12x8	12x8
Table Size in mm	300x200	300x150	300x300	300x500	400x400	200x200	100x100	150x150	200x200	250x250	200x200	150x150	300x200	300x200	200x200
Height in mm	150	150	150	165	170	190	105	120	130	130	65	60	125	145	120
Length Overall in mm	460	460	460	680	620	300	160	275	300	350	295	260	510	510	350
T. Slot Size in mm	13	13	13	16	16	13	13	13	13	13	13	13	14	14	10
Travel Bothways in mm	225	225	225	430, 310	300	125	65	105	125	125	125	105	200	200	125
Width of Jaws in mm	-	-	-	-	-	100	-	-	-	-	One way	One way	-	-	-
Depth of Jaws in mm	-	-	-	-	-	60	-	-	-	-	-	-	-	-	-
Calibration	90°	90°	90°	90°	90°	90°	90°	90°	90°	90°	-	-	-	90°	90°
Wheels graduation in inches	.002"	.002"	.002"	.001"	.001"	.001"	.001"	.001"	.001"	.001"	.001"	.001"	-	-	-
Weight Approx. in kgs	40	36	44	103	80	23	7	14	20	24	12	8	34	35	17



UNIQUE PROCESS MAKES THE **UNIQUE** VICES PRECISION AND STURDY