

UNIQUE

XTRA TUFF VICES

UNIQUE TILTING & SWIVELLING VICE

Code No. U312



U312



FEATURES

- Fitted with Thrust Bearing for Smooth Movement
- Positive locking to withstand heavy loads.
- Horizontal Swivel movement 360°.
- Vertical swivel movement 90°.
- Fine acme thread screw made out of special steel.
- Quick alignment to machine tables using a longitudinal slot.
- One vertical Two horizontal 'V' grooves are provided in hardened and ground jaws
- Crank Handle is made of unbreakable steel provided with a spring loaded mechanism.
- Supplied with Stopper for Fast Production

SPECIFICATIONS

SIZE IN INCHES		2	3	4	5	6	8
A	Width of jaws in mm	50	80	100	125	150	200
B	Opening of jaws in mm	50	75	100	125	150	200
C	Depth of jaws in mm	25	38	42	50	50	60
D	Length overall in mm	210	285	370	450	540	640
E	Height overall in mm	95	225	160	170	195	220
G	Width overall in mm	105	140	170	228	236	280
	Tenon Slot Size in mm	16	16	16	20	20	20
	Weight (Approx) in kgs.	4	8.5	18	30	44	73

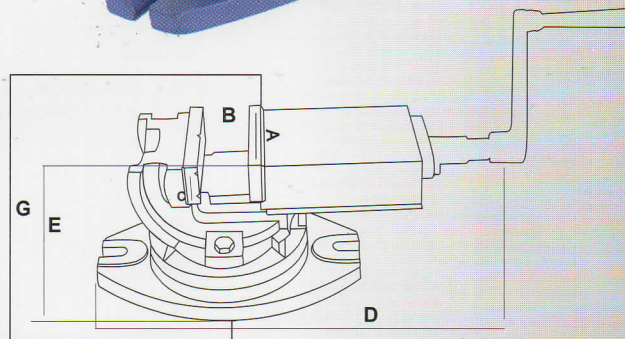

VICES



UNIQUE PROCESS MAKES THE UNIQUE VICES PRECISION AND STURDY